



DC/DC50SD-SEP

v.1.0

DC/DC 5A step down DC/DC converter with separation

EN



Edition: 1 from 21.11.2017
Supersedes the edition: -----

The module's features:

- The DC/DC voltage - step down converter
- Example of use: voltage- step down from 24V to 12V DC
- The input voltage range: 20÷28V DC
- The output voltage range: 12V DC
- The maximum load current 5A (60W)
- Protections:
 - Short-circuit protection SCP
 - Overload protection OLP
 - Over voltage protection OVP
- Galvanic separation between input/output (IN-AUX)
- High efficiency: 87%
- Optical LED indication
- Warranty – 2 years from the production date
- Mounting:
 - Mounting strip with adhesive tape
 - Mounting screws

Example of use of the DC/DC50SD-SEP step down DC/DC converter with separation.

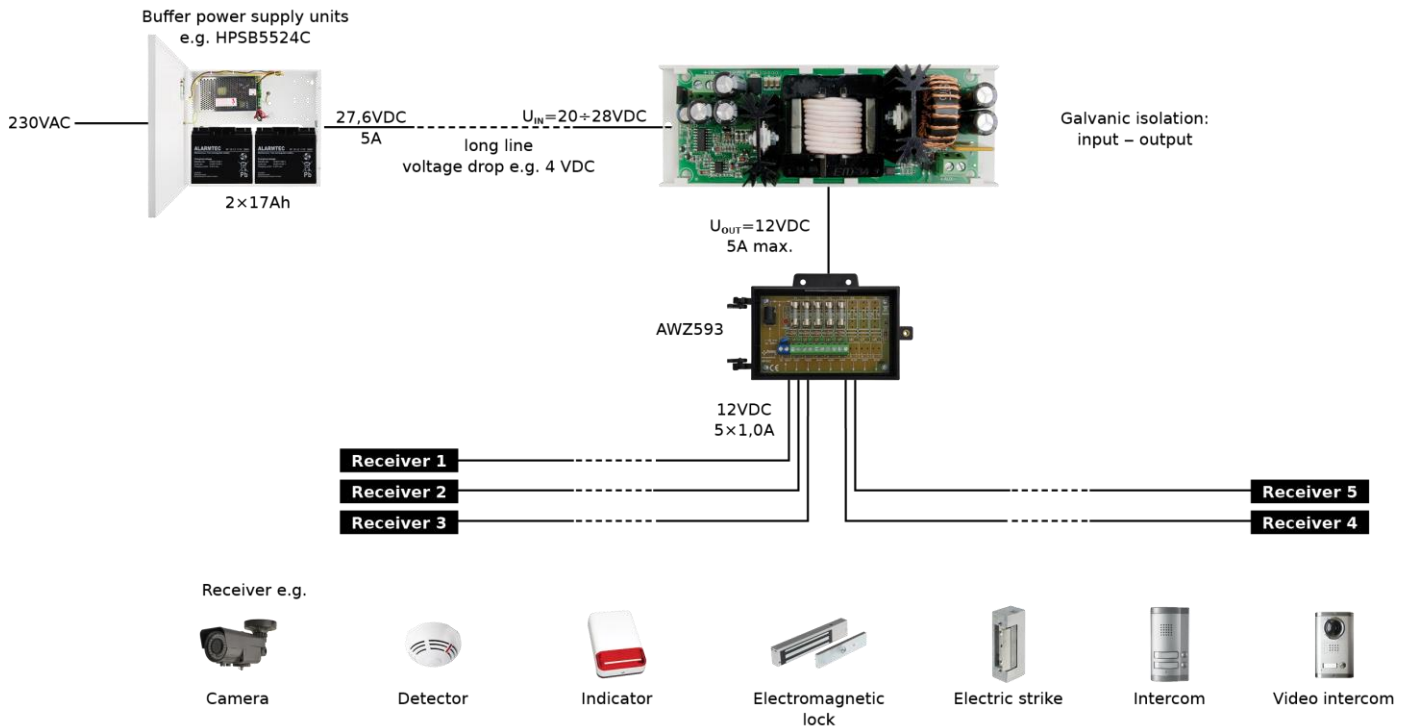

Schematic diagram of the converter operation.

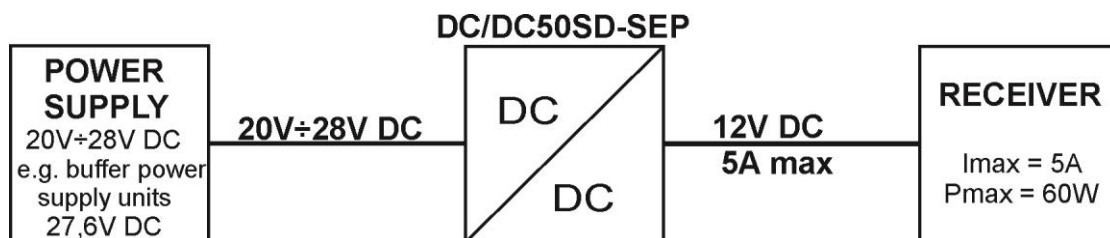

Converter output voltage: 12V DC, 5A max.

1. Technical description

The **DC / DC 5A (DC / DC50SD-SEP)** buck converter is used to reduce the voltage from 20V ÷ 28V DC at the converter input to 12VDC at the output. The maximum load current is $I_{MAX}=5A$ ($P_{MAX}= 60W$). The module is galvanically isolated between the input and output (IN-AUX).

1.1. Block diagram (Fig. 1).

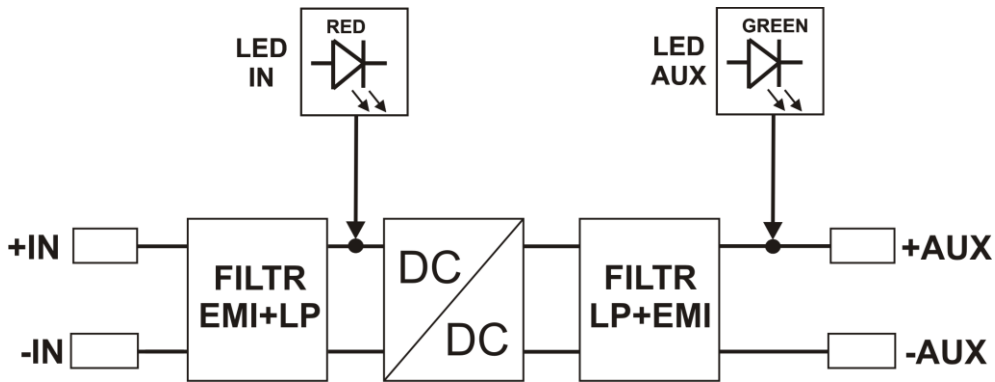

Fig.1. Block diagram of the converter's module.

1.2. Description of components and connectors (Fig. 2, Table 1, Table 2).

Table 1.

No. [Fig. 2]	Component's description
[1]	IN LED light - red
[2]	Power connector of the DC/DC module
[3]	AUX LED light – green
[4]	The DC/DC module's connector
[5]	Mounting strip

Table 2.

[2], [5]	Description of module's connectors
+IN - IN	DC supply input (20V÷28V DC, power consumption from the power source)
+AUX - AUX	DC supply output 12V DC (+AUX= +U, -AUX=GND)

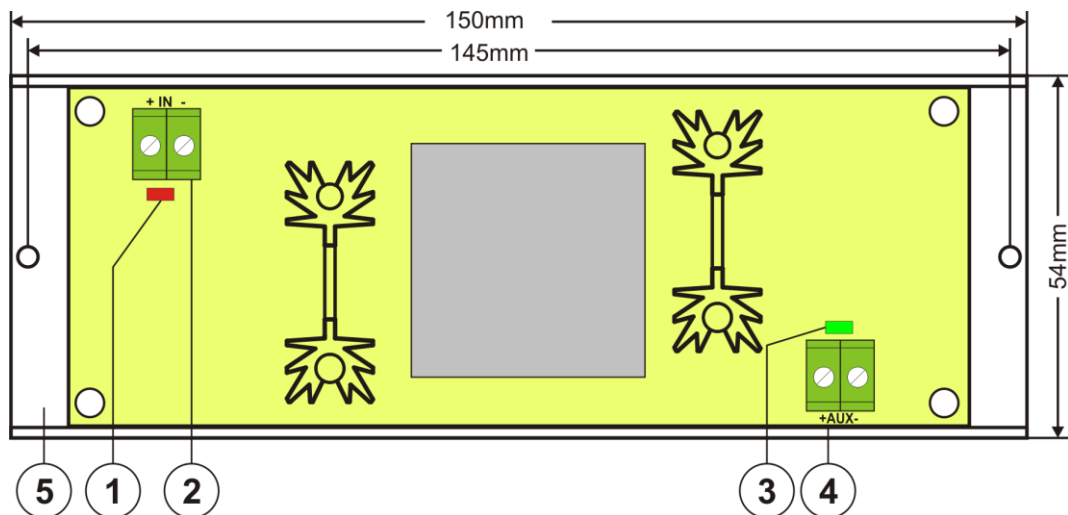

Fig.2. The converter module's view.

1.3. Technical parameters:

- Electrical parameters (Table 3)
- Mechanical parameters (Table 4)

Table 3.

Input voltage (power supply)	20V±28V DC
Output voltage range	12V DC
P module power	60W max.
Energy efficiency	87%
Ripple voltage	50 mV p-p max
Output current	5A max.
Current consumption by module systems	50 mA max.
Short-circuit protection SCP	electronic, automatic recovery
Overload protection OLP	110-150% of the module's power, manual restart (the failure requires disconnection of the DC output circuit)
Overvoltage protection OVP	>16V (activation requires disconnecting the load or supply for about 20 s.)
Optical indication - IN LED indicating DC power status - AUX LED indicating DC supply status at the output	- red, normal status: is lit continuously - green, normal status: is lit continuously
Insulation electrical strength - between the input (IN), and the output circuits of the converter (AUX) (I/P-O/P)	500 V/DC min.
Insulation resistance - between input, output, and protective circuit	100MΩ, 500V DC
Operating conditions	II environmental class, -10°C ÷ +40°C, ensure air flow around the unit for convection cooling
Declarations, warranty	CE, 2 years from the production date

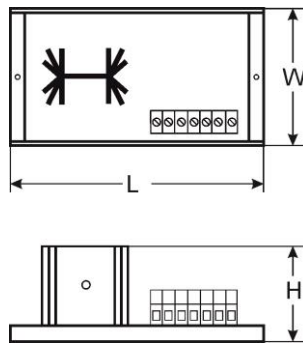

Table 4.

Dimensions	L=150, W=54, H=60 [+/- 2mm]
Mounting	tape or mounting screw x 2
Terminals	Φ0,41÷1,63 (AWG 26-14)
Net/gross weight	0,23/0,27 kg

2. Installation.

2.1. Requirements.

The DC/DC converter is to be mounted by a qualified installer, holding relevant permits and licenses (applicable and required for a given country) for step down installations. The module should be mounted in confined spaces with normal relative humidity (RH=90% maximum, no condensation) and temperature range from -10°C up to +40°C. The module should operate in vertical position in order to provide free and convective air flow.

The module's load balance should be done prior to installation. During normal operation, the total current of the receivers should not exceed **I=5A** while the power drawn from the module should not exceed **Pmax=60W**.

Proper operation of the module requires adequate current capacity of the power source; the power supply capacity should be calculated using the formula below:

$$P_{IN} = 1,15 \times P_{AUX}$$

$$(P_{IN} = 1,15 \times I_{AUX} \times U_{AUX})$$

Example:

The converter will supply the receivers with a capacity of **P_{AUX} = 48W** drawing a total current of **I_{AUX} = 4A** at the voltage **U_{AUX} = 12V**. The minimum power supply capacity must therefore amount to: **P_{IN} = 1,15 x 4A x 12V = 55,2W**.

The device should be mounted in a metal enclosure (cabinet). The rules for power supply, enclosures and shielding - according to application - must be observed in order to meet the requirements of LVD and EMC directives.

2.2. Installation procedure.

1. Mount the enclosure (cabinet, etc.) and lead cables through cable glands.
2. Mount the DC/DC converter with adhesive tape or mounting screws.
3. Supply DC voltage to the + IN, -IN terminals with correct polarization.
4. Connect the receivers' cables to the +AUX, -AUX connectors of the terminal block on the module's board.
5. Switch on the DC voltage (the red IN LED should be permanently illuminated, the AUX green LED should be permanently illuminated).
6. Once the tests and operation control are performed, close the enclosure, cabinet, etc.

3. Converter 's module operation indication.

3.1. Technical output.

The converter is equipped with two diodes indicating operation status: IN, AUX.

- **IN- red LED:** during normal status (DC power supply) it is lit continuously. No DC supply is indicated by switching off the IN LED.
- **AUX- green LED:** indicates DC supply status at the module's output. During normal status, it is lit continuously, in case of short circuit or overload the AUX led is off.

4. Maintenance and operation.

4.1. Overload or short circuit of the converter output.

The AUX output is protected with the PTC polymer fuse. If the load current exceeds I_{max} ($110\% \div 150\%$ @ $25^{\circ}C$ of the converter capacity), the output voltage will be automatically disconnected, which will be signaled by switching off the green AUX LED. Voltage restoration requires disconnecting the output load for approx. 1 min.

4.2. Activation of the overload protection of the power supply unit.

In case of the activation of the overload protection, the output voltage is automatically disconnected. Restart is possible after disconnecting the converter from the power source for at least 20 seconds.

5. Maintenance.

All maintenance procedures can be performed after disconnecting the converter from the power network. The converter does not require any specific maintenance; however, its interior should be cleaned with compressed air if used in dusty conditions.



WEEE LABEL

Waste electrical and electronic equipment must not be disposed of with normal household waste. According to the European Union WEEE Directive, waste electrical and electronic equipment should be disposed of separately from normal household waste.

Pulsar

Siedlec 150, 32-744 Łapczyca, Poland
Tel. (+48) 14-610-19-40, Fax. (+48) 14-610-19-50
e-mail: biuro@pulsar.pl, sales@pulsar.pl
http:// www.pulsar.pl, www.zasilacze.pl